

# 628 Differential Pressure Decay Leak Tester



**The 628 puts Uson's industry leading differential pressure decay sensitivity in your hands and in your budget with no compromise in quality, reliability, and repeatability.**

## FEATURES

- Offers a large, user-friendly, 4.3" TFT graphic display
- Features a standard front challenge port for convenient connections
- Allows for comfortable, table-top usage, with a 15° viewing angle with a small footprint and low profile (5.3" x 12.6" x 13.2")
- Stores up to 512 results to allow review of previous results, including individual program statistics like pass, counters, average, and min and max values
- Includes an export/import option to backup and retrieve tester settings, and allows the transfer of these settings to other testers
- Supports external outputs, including Pass, Reject +, Reject -, Alarm, and EOC
- Includes pressure & vacuum options
- Offers an electronic regulator option for testing multiple pressures
- Includes internal or external vacuum supply options
- Supports external inputs, including Start, Abort, and Program Selection
- Sends readable, text-formatted reports or result audit output to a USB memory device, internal memory file, or serial port
- Protects electronics with a dust-proof and waterproof enclosure
- Incorporates a flat, seamless front panel for easier cleaning
- Allows across-the-room viewing of at least 10 feet, with accentuated Pass/Fail lights
- Reduces unintentional interference of the regulator by operators by connecting the regulator in rear of the instrument
- Supports English, Chinese, and Spanish languages, with additional languages on request
- Calibration Port Options: Mini Swagelok, Swagelok, Staubli

## **System Description**

When speed and accuracy are important to a process, Uson's 628 Differential Pressure Decay Leak Tester is the ideal solution. Where typical differential testing methods can be complex and expensive, Uson's 628 leak tester delivers unmatched accuracy and reliability.

With the 628, Uson has reinterpreted the classic automatic leak tester into a powerful-yet-simple instrument that can run multiple tests, including differential pressure decay, differential vacuum decay, and compensation and calibration programs.

The Uson 628 leak tester serves the automotive, industrial and medical device industries, helping to identify quality issues to increase yield and improve production efficiency. By identifying leaks early in the process, the 628 helps to reduce the likelihood of product deviations or recall issues.

As a highly flexible and budget-friendly choice in leak detection, the 628 allows users to choose from four different pressure ranges from vacuum up to 225 psi (15 bar) to cover a wide range of applications from medical check valves to automotive radiators and more. Plus, it is possible to create and save up to 30 test programs for fast recall.

## **Uncompromising Precision and Accuracy**

With an intelligently designed user interface, the easy-to-use Uson 628 leak tester delivers clear, non-subjective results with the level of performance expected from more complex and expensive instruments.

The Uson 628 provides users on a tight budget with the precision and accuracy delivered by industry-leading differential pressure decay transducers.

## **Easily Accommodates Multiple Test Pressures**

For applications that need to test a multiple test pressures, the 628 offers an optional electronic regulator. With the electronic regulator option, the 628 can be programmed to test a part at different test pressures in a sequence. Additionally, the test programs can be linked, serving to further the automation of the test sequence. Another benefit with the electronic regulator is that it adds an increased level of security. It is only accessible through the programming interface and can be locked and safeguarded to prevent unintended changes. This is a significant advantage over a manual regulator, which can be adjusted from the back of the instrument.

## **Tests Capabilities of the 628 and Test Definitions**

The 628 uses the differential pressure decay testing methods, and includes options for compensation and leak rate calibration.

### **Differential Pressure Decay**

Differential pressure decay is a more sensitive variant of gauge pressure decay. Differential pressure decay testing involves pressurizing both the test component and a reference volume, typically a non-leaking component of the same volume. The pressure differential between the non-leaking reference volume and the test component is measured by a differential pressure transducer over time.

### ***How Differential Pressure Decay Works:***

1. The fill step pressurizes the test part and the reference port. The pressure is monitored by the gauge sensor for this step.
2. At the beginning of the stabilize step, the fill valve closes so that no more air is allowed into the test part. The time is set so that the air pressure stabilizes the adiabatic effects from

pressurizing the test part. The gauge sensor is used for this step to verify that the gauge pressure is within the specified limits. If too much pressure loss occurs during this step, the part either has a gross leak or the fill time is not long enough.

3. At the beginning of the equalize step, valves close to separate the test port and reference port of the differential sensor. This step is used to allow time for the valves to switch and for any pressure pulses that may have occurred when the valves switch to settle out. The differential sensor is the sensor that needs to be monitored at the end of this step. It is important that the differential sensor has range available when entering the measure/fine leak step.
4. The test and reference ports are still separated from each other during this step. The

differential sensor is monitored for pressure changes from the beginning to the end of the step. This measurement is sometimes referred to as Delta P. Depending on the measure type of this step, it is possible to have the step answer in pressure change or leak rate, i.e., cc/min. The differential sensor is used for this step. If the measure type is pressure change, limits will be in mbar or other engineering units. If the measure type is in leak rate, the limit units will be in cc/min or other volumetric engineering units.

5. The vent step is used to vent the air pressure from the part. The circuit naturally vents when it is not running a test, so the time is used to delay the final decision until all the air escapes and it is safe to remove the part from the tester.

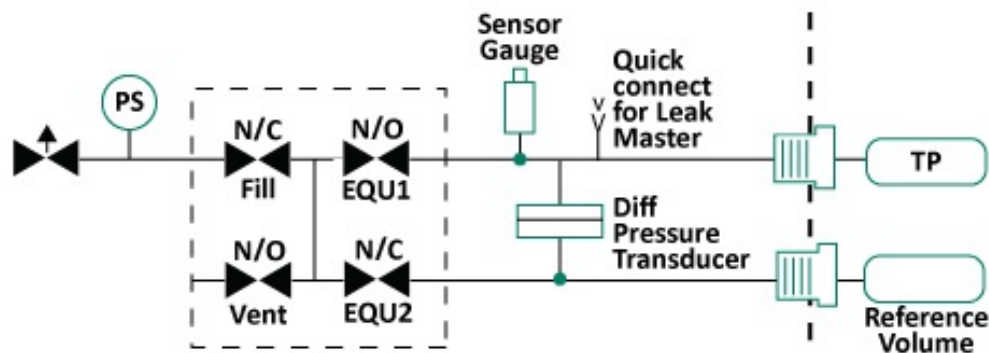

Differential Pressure Decay Test Pneumatic Diagram

## Differential Vacuum Decay Test

The differential vacuum decay test is similar to the differential pressure decay test, except that the system is evacuated using an internal or external vacuum.

### How Differential Vacuum Decay Works:

1. The part to be tested [TP] is attached to the test port, the non-leaking reference part is connected to a separate test port, and the test is started.

2. The 628 leak tester evacuates the part and reference with negative pressure [-P] to the desired test pressure set by opening the fill valve and the equalization valve (EQU2) and closing the vent valve during the first step, the fill step.
3. At the end of the fill step, pressure is then trapped inside the part and reference. The fill valve, EQU1 and EQU2 valve are closed.
4. Trapped pressure inside the test circuit is held through step two, the stabilize step, and then

measured by the 628's differential pressure transducer during the test step.

5. If the part exceeds the programmed leak tolerance (pressure rise over time or quantified leak rate), the 628's display indicates the reason for the test failure and displays the pressure gain or leak rate in user defined units of measure.
6. At the end of step three, the test step, the part

and the reference are equilibrated to the atmosphere by opening EQU1, EQU2 and the vent valves, and the 628 is ready to make the next test.

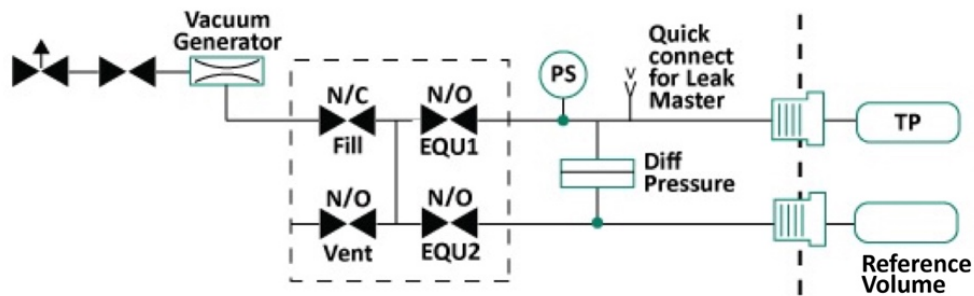

Differential Vacuum Test Pneumatic Diagram

## Leak Rate Calibration

Leak rate calibration is a two-step process that is required to deliver accurate and leak rate measurements. First, the test is run with a non-leaking master part to establish the characteristic pressure change of the part and the pneumatic system. This result is referred to as the compensation value (comp). Compensation is performed in order to improve sensitivity by reducing noise due to electrical, pneumatic, thermal, and atmospheric influence. The second test is run with a traceable Leak Master to introduce a known leak to the master part. This process establishes pressure loss caused by a leak, and the resulting value is referred to as calibration (cal).

## How Comp and Cal Testing Works:

1. The appropriate test type and pressure are chosen.
2. Leak rate precision, units, and Leak Master values are entered through the Leak Calibration menu.
3. A non-leaking test part is attached to the desired port and the comp test cycle is selected.
4. The test will cycle through its usual steps and stop with a green light, and the result is assigned to the comp value.
5. A leak master is attached in-line with the non-leaking part, and the cal test cycle is selected.
6. The test is re-started.
7. The steps should cycle through as before and result in a green pass light, and the result is assigned to the cal value.
8. This information is saved and the unit is calibrated for future tests.

**Specifications**

| <b>LEAK RATE MEASUREMENT</b>     |   |
|----------------------------------|---|
| Sensor Type                      | Capacitive differential   |
| Range                            | 20 mbar/2000 Pa/0.29 psig   |
| Resolution                       | 0.01 mbar/1 Pa/0.0001 psig  |
| Accuracy                         | ± 1% range  |
| <b>TEST PRESSURE MEASUREMENT</b> |   |
| Sensor Type                      | Solid State   |
| Ranges                           | -950 mbar/-95 kPa/-14 psig<br>1 bar/1000 kPa/15 psig<br>4 bar/400 kPa/60 psig<br>10 bar/1000 kPa/150 psig<br>15 bar/1500 kPa/225 psig |
| Accuracy                         | ± 1% of gauge pressure range  |
| <b>GENERAL SPECIFICATIONS</b>    |   |
| Number of Programs               | 30  |
| User Interface                   | Display, LCD, 4.3"<br>Start & Reset buttons<br>Tactile programming keys<br>Pass/Reject LED light bars                                 |
| Interface                        | Serial, External I/O Control, and USB   |
| Supply Input                     | 24 VDC  |
| Air Supply                       | Clean, dry air, 4-15 bar<br>(60-225 psig)   |
| Pressure Regulation              | Manual or Electronic  |
| Calibration Port                 | Mini Swagelok, Swagelok, Staubli  |
| Dimensions (H x D x W)           | 5.3 x 12.6 x 13.2 inches (134 x 320 x 335 mm)   |
| Weight                           | 22 lbs. (10kg)  |
| Pressure Units                   | psig, bar, mbar, Pa, kPa, kgcm <sup>2</sup> , mmH <sub>2</sub> O, cmH <sub>2</sub> O, inH <sub>2</sub> O, mmHg, cmHg, mHg             |
| Manufacturing Standards          | ISO 9001:2015<br>Certified to CE requirements<br>RoHS<br>WEEE   |
| <b>ACCESSORIES</b>               |   |
| Serial Printer Kit               | 690214 (US), 690215 (UK), 690216 (EU)   |
| Remote I/O Pendant               | 690210  |
| Q6 I/O Adapter                   | 690200  |
| Oil-less Vacuum Pump             | 690211 (US), 690212 (UK), 690213 (EU)   |

*Due to a program of continuous development, specifications may be changed without notice.*

**Product Configurations and Options**

**U628-abc-def**

| a<br>(Model Type)               | b<br>(Regulator Type)                      | c<br>(Pressure Range)  | d<br>(Language)                           | e<br>(Pneumatic)   | f<br>(Power Cord)                            | G<br>(Cal Port Type)                        |
|---------------------------------|--|--|---|--|--|---|
| D = Differential pressure Decay | M = Manual<br>E = Electronic<br>V= M16 Vac | 1 = Vacuum<br>2 = 15 psig<br>3 = 60 psig<br>4 = 150 psig<br>5 = 225 psig | E = English<br>C = Chinese<br>S = Spanish | 0 = None<br>1 = Ext Vacuum Port<br>2 = Internal Venturi<br>3 = External Vent Valve | 1 = USA<br>2 = UK<br>3 = China<br>4 = Europe | 1-Mini Swagelok<br>2- Swagelok<br>3-Staubli |

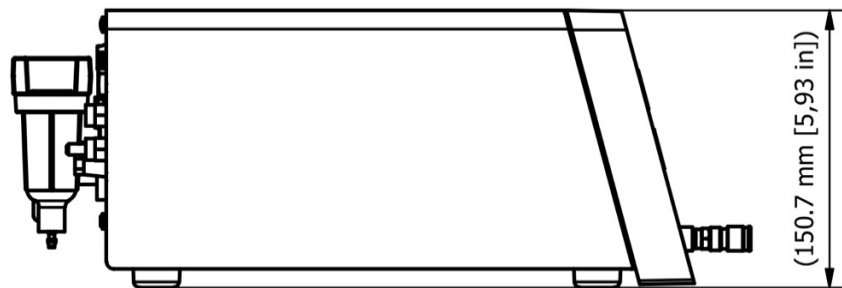

*A fifteen-degree viewing angle makes bench top programming steps easy to follow, while large illuminated pass and fail lamps are highly visible from far away.*

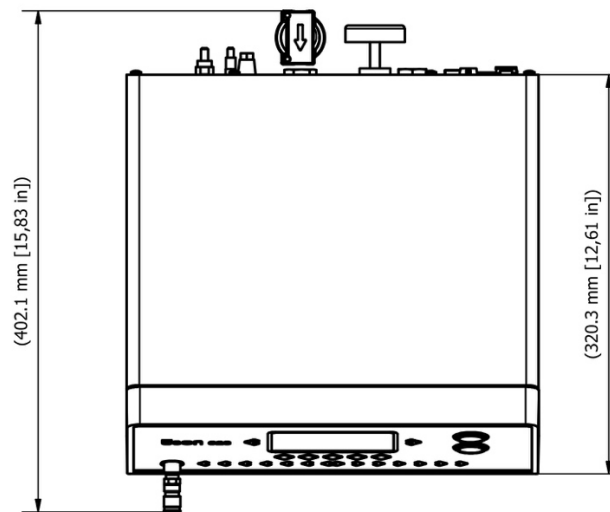

*The 628 leak tester reduces the likelihood of product deviations or recall issues through early identification of leaks.*

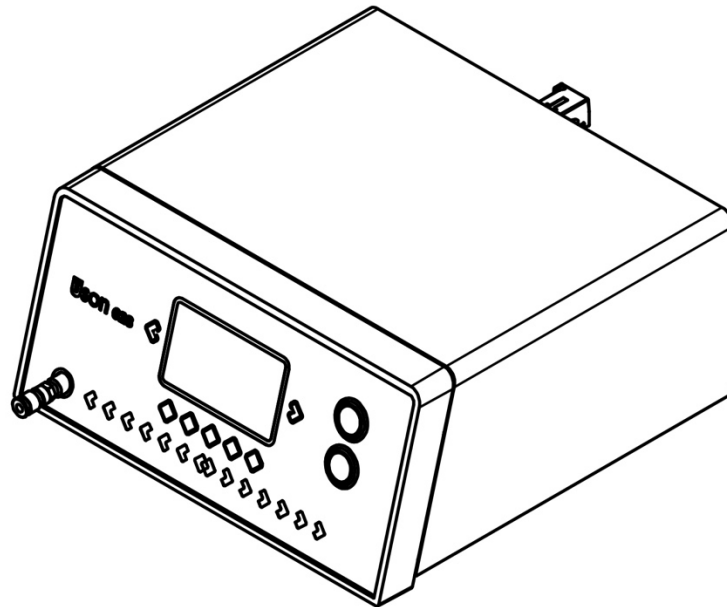

The 628 leak tester comes with a durable, splash-proof, and dust-proof enclosure to protect electronics.

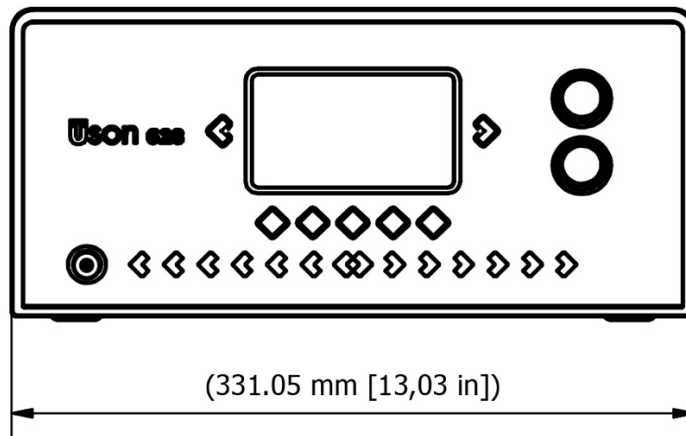

The 628 leak tester has a high, 24-bit resolution for accurate measurements.